

### DESCRIPTION

The OZ450 Series consists of compact individual Tx and Rx modules, with high performance designed for RF over Fiber Optics (RFOF) applications. These modules are designed to be Pluggable, using optional miniature 50 ohms SMB connectors for quick implementations and conversion of any RF signal (on board) to optical signal in 1310 nm wavelengths. They are designed to be compact with built in RF shield to support low EMI/RF interference for Single Mode Fiber or optional Multimode Fiber applications.

These linear RFOF Links offer an excellent alternative to legacy coaxial cable systems. The OZ450 delivers significant improvements in the transport of RF signals in their native format, reliably, over many types of optical networks, and across a broad range of frequencies. The low NF and high IP3 performance is the perfect solution for high Spurious Free Dynamic Range (SFDR) applications within a broad range of operational frequencies. An optional extended bandwidth of 1 MHz to 3.3 GHz is also available.

The standard optical connector is SC/APC (FC/APC available) for low back reflection applications. The Receiver features a high performance InGaAs photodiode and the Transmitter is based upon a linear optically Isolated FP Laser operating at 1.3  $\mu\text{m}$  (A) over 9/125  $\mu\text{m}$  Single Mode Fiber. Average Automatic Power Control (AAPC) is incorporated for optimal optical power stability over the full temperature range. The RF interface is via a 50 Ohms SMA or SMB (Plug or Jack) connector. Alarm and monitoring functions are available through a 10 pin connector.

### FEATURES

- 30 MHz to 2.7 GHz Bandwidth
- Approx Size: 1.5 x 2.5 x 0.6 in.
- -40°C to +75°C Operating Temperature Range
- LD/PD Monitoring & Alarm
- High SFDR
- Automatic Optical Power Control
- 1.3  $\mu\text{m}$  Low Noise FP Lasers
- Laser Conforms to Class 1 Emission Level per CDRH and IEC-825 (EN 60825) Standards

### OPTIONS

- Extended Bandwidth of 1 MHz to 3.3 GHz
- Built-in Low Noise Amplifier in the Tx module
- Multimode Fiber Compatibility

### APPLICATIONS

- Wi-Max
- 4G LTE
- Cellular Backhaul
- Avionics
- MMDS
- Remote Antenna Location
- Satcom
- In-Building DAS Solutions
- GPS Distribution
- Timing Delay

### ABSOLUTE MAXIMUM RATING

Parameter	Symbol	Min	Max	Units
Storage Temperature (Case)	T <sub>s</sub>	-40	+85	°C
Operating Temperature (Case)	T <sub>o</sub>	-40	+75	°C
DC Supply Voltage	V <sub>PD</sub>	+11.5	+12.5	Volts
Maximum RF input into Tx (no LNA)			+15	dBm
Maximum RF input into Tx with LNA			0	dBm
Maximum Optical Input into Rx			4	mW

### CHARACTERISTICS OF OZ450

Parameter	Symbol	Min	Typical	Max	Units	Notes
Power Supply Voltage	VCC		12		Volts	
Power Supply Current TX	IC <sub>Ctx</sub>		60	80	mA	1
Power Supply Current RX	IC <sub>Crx</sub>		155	175	mA	1
Laser Optical Output Power			2		mW	
Transmitter Operating Wavelength A/B	$\lambda$		1310		nm	
Receiver Operating Wavelength B/A	$\lambda$		1310		nm	
High Frequency Cutoff	HFC		2700	3300	MHz	2
Low Frequency Cutoff	LFC	1	30		MHz	3
Frequency Response (30 to 2700 MHz)			+/- 1.5		dB	
Input/Output Impedance	Z		50		Ohms	
Input/Output VSWR (30 to 2700 MHz)			1.5:1	1;8:1		
Spur Free Dynamic Range	SFDR		109		(dB/Hz) <sup>2/3</sup>	4
RF Link Gain		-1	0	+1	dB	4
Input Noise Floor	EIN		-133		dBm-Hz	4
Input Third Order Intercept	IIP3		31		dBm	4

1. Does not included custom Gain, NF and IIP3 configurations, contact factory for more details
  2. Typical High Frequency Cutoff (HFC) is 2700 MHz. For higher HFC contact Factory.
  3. Typical Low Frequency Cutoff (LFC) is 30 MHz. For lower LFC contact Factory
  4. Measured with 1 meter of Single Mode Fiber.
  5. Other variations of Gain, NF and IIP3 are available upon request. Contact factory for more details
- All measurements are taken at @ 25°C.

### CHARACTERISTICS OF OZ450 Link with LNA (in the Tx)

Parameter	Symbol	Min	Typical	Max	Units	Notes
Power Supply Voltage	VCC		+12		Volts	
Power Supply Current TX	ICCTx		140	160	mA	1
Power Supply Current RX	ICCrX		155	175	mA	1
Laser Optical Output Power			2		mW	
Transmitter Operating Wavelength A/B	$\lambda$		1310		nm	
Receiver Operating Wavelength B/A	$\lambda$		1310		nm	
High Frequency Cutoff	HFC		2700	3300	MHz	2
Low Frequency Cutoff	LFC	1	30		MHz	3
Frequency Response (48 – 2700 MHz)			+/- 1.5		dB	
Input/Output Impedance	Z		50		Ohms	
Input/Output VSWR (48-2700 MHz)			1.6:1	1:8:1		
Spur Free Dynamic Range	SFDR		109		(dB/Hz) <sup>2/3</sup>	4
RF Link Gain		19	20	21	dB	4
Input Noise Floor	EIN		-152		dBm-Hz	4
Input Third Order Intercept	IIP3		12		dBm	4

- Does not include custom Gain, NF and IIP3 configurations, contact factory for more details.
  - Typical High Frequency Cutoff (HFC) is 2700 MHz. For higher HFC contact Factory.
  - Typical Low Frequency Cutoff (LFC) is 48 MHz, For lower LFC contact Factory
  - Measured with 1 meter of Single Mode Fiber.
  - Other variations of Gain, NF and IIP3 are available upon request. Contact factory for more details
- All measurements are taken at @ 25°C.

### 10 PIN CONNECTOR CONFIGURATIONS

Pin	Tx	Rx	Pin	Tx	Rx
1	Laser Enable (+12V)	NC	2	NC	NC
3	Ground	Ground	4	NC	NC
5	+12 Volts	+12 Volts	6	NC	NC
7	Tx Monitor	Rx Monitor	8	NC	NC
9	Tx Alarm Open Collector	Rx Alarm Open Collector	10	NC	NC

LED Indications	GREEN	RED
Transmitter	Laser Bias Current Normal < 110 mA	Laser Bias Current Fault
Receiver	Input Optical Power Normal >-10dBm	Input Optical Power Fault

RF Connectors = SMB PCB Mount Plug/Jack or SMA Plug Horizontal

Optical Connectors = SC/APC (Optional FC/APC or LC/APC)

Supply + Monitor + Alarm = 10 Pin Connector

### ALARM

Transmitter Dual Color LED Laser Bias Indicator.

Receiver Dual Color LED received Optical Power Indicator.

### INDIVIDUAL Tx ALARM & MONITORING CIRCUIT DIAGRAM

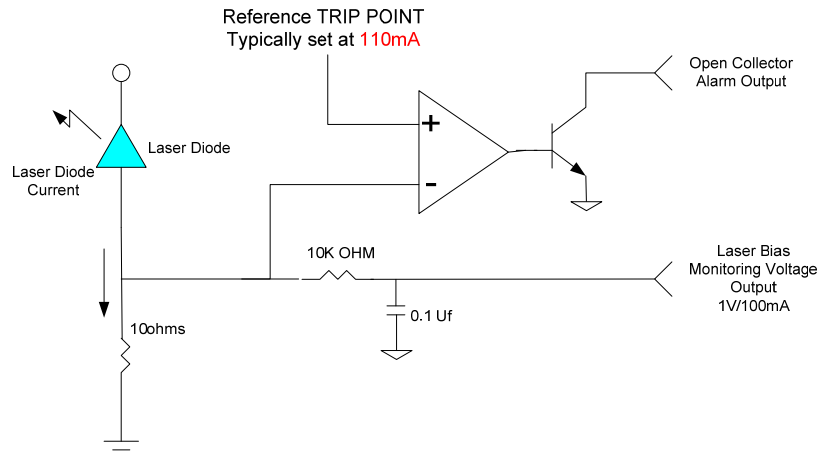

### INDIVIDUAL Rx ALARM & MONITORING CIRCUIT DIAGRAM

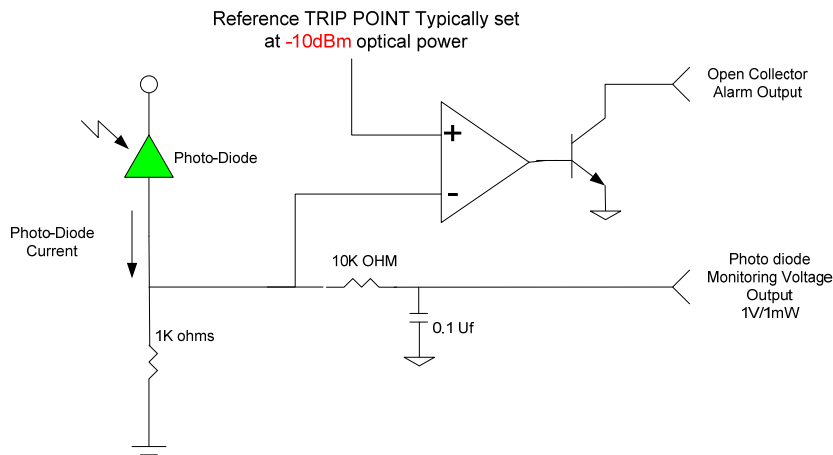

All alarms are Open Collector topology, with Active Low for Normal operations and during Alarm condition the Open Collector will Pull to High logic levels. Reverse polarity alarm is also available upon request. Under normal conditions the Open Collector will be High and vice versa under fault conditions.

### MECHANICAL DRAWING

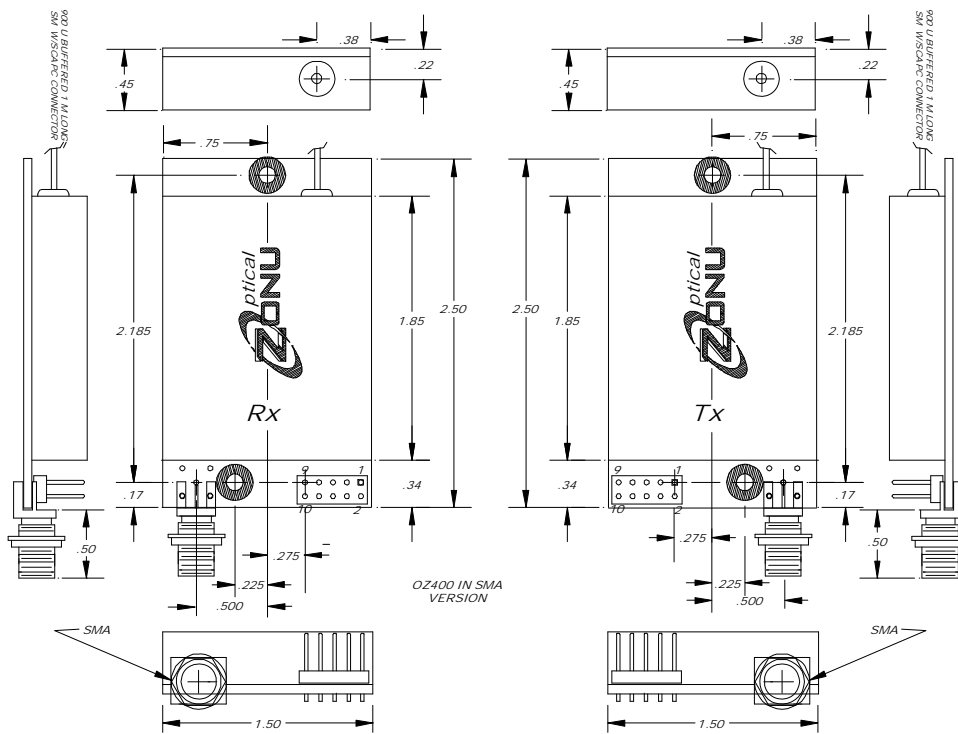
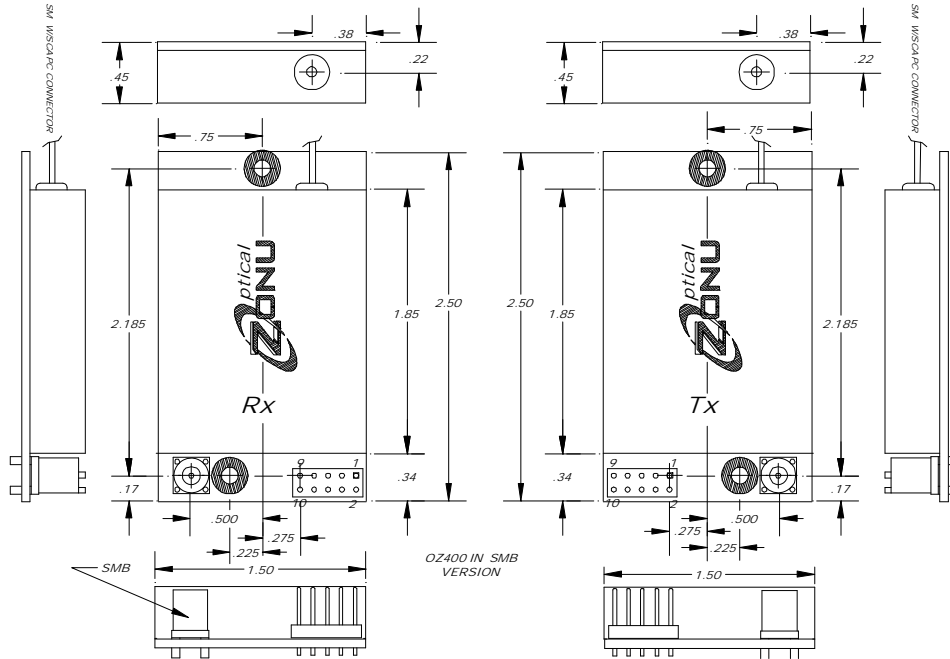

**ORDERING INFORMATION**

**PART NO. AX3- Z450 – F31 – XX – X X**

**L** – LNA (*applies only to A03, A13*)  
**0** – No LNA

**0** – Unidirectional Link with Tx & Rx  
**1** – Transmitter Only (Tx)  
**2** – Receiver Only (Rx)

**S** – Single Mode Fiber Compatible  
**M** – Multimode Fiber Compatible

**A** – SMA  
**B** – SMB

**S** – SC/APC  
**F** – FC/APC

