

Gigabit SFP Transceiver with Integrated Optical Time Domain Reflectometer for Ethernet Access Services

Neil Parkin⁽¹⁾, Meir Bartur⁽²⁾, Derek Nasset⁽¹⁾, David Jenkins⁽²⁾

⁽¹⁾ BT Research & Innovation, Adastral Park, Martlesham Heath, IP5 3RE, UK, neil.parkin@bt.com

⁽²⁾ Optical Zonu Corp., 15028 Delano Street, Van Nuys, CA 91411-2016, USA, meir@opticalzonu.com

Abstract: An SFP transceiver with integrated OTDR is used with a commercial Ethernet network termination unit and the OTDR functionality evaluated. We show length measurement readings within 90 m of those obtained from a dedicated commercial OTDR tester. The use of OTDR can reduce network downtime by quick reliable location of faults.

Introduction

Dedicated point-to-point (PtP) optical links are widely used to offer business access services. These are premium services which adhere to strict service level agreements (SLAs) that often include a maximum time the link will be unavailable after a fault. If the down time SLA is exceeded, the Service Provider (SP) may be liable to pay compensation to the customer. Typically, service faults need to be diagnosed and rectified within a few hours.

Optical Time Domain Reflectometry (OTDR) has been proposed¹ as a method to provide rapid measurement of a fibre fault location. Typically, such fault location systems² exploit a standalone OTDR tester that is shared³, via an optical switch⁴, among many access links to lower the cost per monitored line. These systems require additional fibre connections in the central office and extra rack space. Furthermore, the optical switch loss will impact the overall link budget and may, itself, become a new point of failure. However, if the transceiver used for the data connection also had the dual function of being able to identify and locate a fibre fault⁵, this would enable rapid fault

diagnosis and resolution to the benefit of both the subscriber and SP.

Fig. 1 illustrates the process for quick dispatch of an appropriate engineer to the fibre fault location. This is achieved by the removal of human intervention until the alarm reaches the operations support system. This allows the SP to gain improvements compared to the current method of sending an engineer with a field OTDR to the central office or customer premises to identify the fault.

SFP Module with Integrated OTDR

The SFP module is a single-fibre working unit that, unlike most SFP transceivers, can use a single wavelength for the transmitter and receiver. This allows the fibre capacity to be doubled because each wavelength is used in both directions. This optical arrangement also enables the transceiver to operate as an OTDR.

The optical sub-assembly uses a 50/50 ratio splitter to separate the signals travelling in each direction. This approach requires careful electro optical design to avoid crosstalk from the transmitter affecting the highly sensitive receiver.

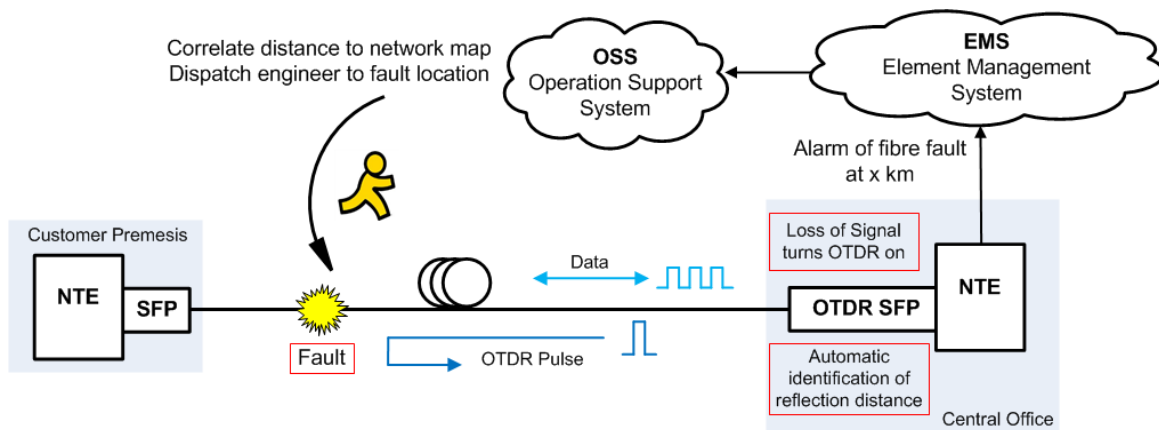

Fig. 1: PtP Access link showing engineer dispatch using OTDR SFP

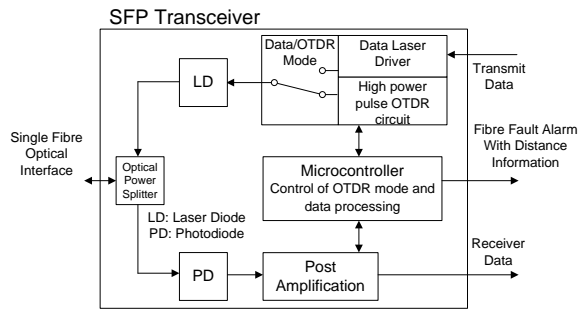

Fig. 2: SFP OTDR Module block diagram

Figure 2 shows the transceiver block diagram. To operate as an OTDR, the SFP transceiver switches from operating as a data-link into OTDR mode. This can be manually forced or automatically initiated upon a loss of signal (LOS) alarm detected by the receiver circuits. The laser is driven by electrical pulses and emits optical pulses of $> +13\text{dBm}$ with a fixed length of a $<1\mu\text{s}$. The receiver detects the reflected pulses down to $\leq -42\text{dBm}$ optical power, for a dynamic range of $\geq 55\text{dB}$.

In operation, a decision circuit identifies the return pulse and a microcontroller measures the delay and converts this to a distance. To ensure accuracy the reflection is measured multiple times by the unit prior to reporting the distance.

When the transceiver is first powered, it takes an OTDR measurement and records up to 15 locations of reflections. These can be useful in analysing any subsequent faults.

Fibre faults and intermittent connections present optical reflections of varying magnitude. The statistical distribution of the reflection magnitude of a fibre cut has been previously reported⁵. This study showed that, to achieve a detection probability of greater than 95% for a fibre cut, the unit must identify reflections due to faults down to -51dB . This would need to be achieved up to the maximum link length. It is possible to conceive to increase the detection probability in a multi-fibre cable by monitoring multiple fibres as each fibre breaks differently, and it may be sufficient to detect a break in only one fibre in the bundle.

In addition intermittent faults can be located as the OTDR reading is triggered and stored within a few milliseconds, so even the inadvertent disconnection and reconnection of a connector is recorded.

System Experiment

The OTDR SFP transceiver ($\lambda = 1557\text{nm}$) was inserted into a commercial (ADVA FSP150) Ethernet Network Termination Equipment (NTE). A firmware modification allows the

distance to a fibre fault to be extracted from the SFP by the NTE. In a real network application, an SNMP agent in the NTE would inform the network element manager of the fault distance as measured by the transceiver.

The accuracy of the OTDR SFP distance measurement was compared with a commercial standalone OTDR (Anritsu MW9076D) configured with a $1\mu\text{s}$ pulse width and using both 1310nm and 1550nm sources to determine the fault distance. This is the same type of unit used by field engineers to locate a fibre fault and has an accuracy⁶ of ± 2.1 meters for the given measurement conditions.

The experiment used reels of Corning® SMF 28e™ single mode fibre (SMF) with an unmated SC/UPC connector (reflectivity = -15dB) to simulate a fault. The distances measured by the external OTDR were compared with the integrated SFP OTDR configured with a single-pass measurement (i.e. no averaging).

The sensitivity of the OTDR SFP to the reflectivity of a fibre fault was measured by varying the reflected power using the setup illustrated in Fig. 3. Again, an unmated SC/UPC connector was used to provide a reflection and the overall return loss adjusted using a Variable Optical Attenuator (VOA). The fibre link length was varied using appropriate SMF reels. The attenuation was increased for each SMF length to the point where the SFP was no longer able to detect the reflection. Then the attenuation was decreased incrementally to find the largest Optical Return Loss (ORL) that could be detected by the SFP at each link distance.

The repeatability of the measured distance to the fault by the OTDR SFP was also evaluated. An unmated SC/UPC connector was used at the end of various lengths of SMF and 10 readings taken from the OTDR SFP. This was repeated using a variable back reflector in place of the unmated SC/UPC connector to produce a reflection of -30dB .

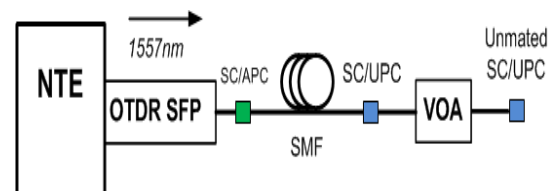

Fig. 3: Configuration for sensitivity tests

Results and Discussion

The measurement results in Fig. 4 show that, relative to the external OTDR, the distance measurement for the SFP OTDR was within ± 90

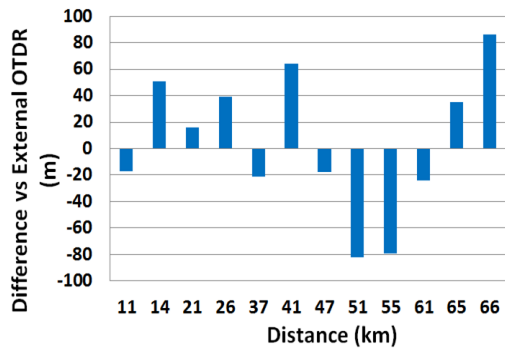

Fig. 4: Measurement difference of fault location by SFP in comparison to commercial OTDR

metres. This level of accuracy allows the location of a fault to be correlated with the network cable route records to determine the map coordinates to send an engineer.

As shown in Fig. 5, the OTDR SFP was able to measure an event on the link with an ORL of >50dB at 250m and 25dB at 65km. The results are linear over the distance measured and show that the OTDR SFP is consistently able to measure the same reflected power over distance, with only the attenuation of the link affecting the level detectable. The fibre attenuation calculated from the linear fit is 0.192dB/km. This corresponds well with the manufacturer's datasheet⁷ value of 0.19dB/km to 0.2dB/km for 1550nm wavelength. The SFP OTDR in this experiment would be able to measure over 50% of breaks (ORL of 42dB, based on reported statistical distribution of cuts⁵) up to 30km distance. In an access link using SC/UPC connectors, faults from unmated connections would be detectable up to 65km.

The OTDR SFP tested was designed to measure up to ~65km which is sufficient for most access point-to-point networks. Monitoring from each end would allow 130km of fibre to be covered but would require an alternative route back to the EMS to report the fault e.g. using radio.

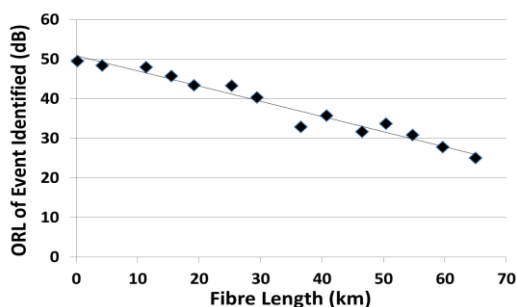

Fig. 5: OTDR SFP sensitivity to ORL event.

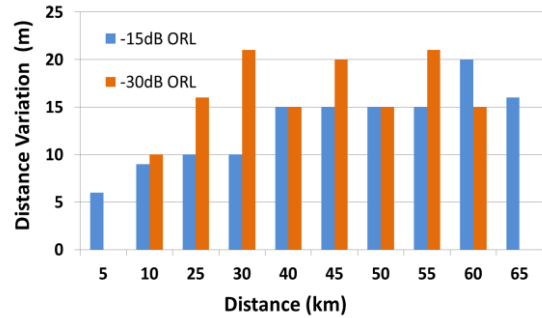

Fig. 6: OTDR distance repeatability

The repeatability of the measurement of fault location decreases with distance as shown in Fig. 6. At 5km no variation (within the measurement resolution) was measured for the -30dB reflection. At 65km the -30dB point reflection could not be detected. A worst case variation of 20m and 21m was measured for -15dB and -30dB reflection respectively.

Conclusions

An SFP OTDR transceiver was evaluated. The integrated OTDR has the potential to aid SPs in reducing costs by minimizing time to repair a fibre fault and also to improve the customer experience.

The SFP OTDR was tested for accuracy, sensitivity to reflection and repeatability of the OTDR measurement. The measurements show accuracy within ±90 metres which would allow an OSS operator to identify a physical network location to send a repair engineer. The repeatability measurements (variation ≤21m) ensure that multiple engineer trips should not be required. The sensitivity to ORL (>50dB at 250m to 25dB at 65dB) will allow a wide range of fibre breaks to be detected dependant on fibre distance.

Acknowledgements

We wish to thank ADVA Optical Networking and, in particular, Tung Le and Peter Turnbull for their invaluable contribution to this study.

References

- [1] K. Yuksel, et al., ICTON 2008 Tu.B1.1
- [2] N. Tomita, et al., IEEE JLT, pp. 717–726, May 1994.
- [3] J. Chen et al, OFC 2013 JTh2A.07
- [4] N. Honda NTT., OFC 2012 OTu1H.1
- [5] A. M. Bartur, B. M. J. Hartmann, and C. D. Jenkins, OECC 2012, paper 4A2-5
- [6] Anritsu® MW9076 Series V3.00 Datasheet
- [7] Corning® SMF 28e™ G.652.D Datasheet